

Research Report

Validation of 2-Butanone (MEK) using SKC Passive Sampler 575-002

Abstract

A sampling method for 2-Butanone (MEK) in air has been validated for concentration levels from 20 to 400 ppm and for exposure times from 7.5 minutes to 12 hours. The 575-002 passive sampler used has a sample medium of Anasorb® 747. Desorption was with 5% 2-butanol in carbon disulfide and analysis by gas chromatography with flame ionization detection.

The analytical recovery over the range of 20 to 400 ppm (0.47 to 10 mg) was 100% with a relative standard deviation of 0.80%.

The sampling rate is 17.1 ml/min. Samples can be taken from 10°C to 40° C.

Minimum recommended sampling time is 15 minutes. Maximum recommended sampling time is 12 hours.

Storage stability at freezer (-8° C) temperatures showed no significant loss in recovery after 25 days. Precautions must be taken when stored at room temperature (25° C). Recovery was reduced to an average of 76.9% after 4 days at room temperature. Do not store at room temperature.

A full validation of Acetone was done according to NIOSH Protocol¹ and a partial NIOSH validation by the Bi-level procedure was conducted for MEK and other higher members of this homologous series.

Authors

Linda S. Coyne
Robert J. Orr
Martin Harper
Lloyd V. Guild

Compiled by Linda S. Coyne

SKC Inc.
863 Valley View Road
Eighty Four, PA 15330 USA

Importance of Validation of Passive Samplers

There are distinct differences between a passive sampler and a sample tube.

The most important difference is that a passive sampler does not have a foolproof back up section that guarantees that all the chemical hazard has been collected and there is a true and total measure of the worker exposure.

Secondly, the sorbent media is exposed to the external environment and this poses problems not associated with a sample tube where the air sample passes into the sample tube directly contacting the sorbent media. That is why it is critical to use a strong sorbent medium in passive samplers to assure complete capture and retention.

Therefore, for compliance purposes a passive sampler must be laboratory tested and validated under worst case field conditions for all factors that affect sampling accuracy as well as interaction between affects.

NIOSH has laid out a rigorous and complete validation protocol to assure that the sample collected is a complete and true measure of worker exposure. The following are the factors that the NIOSH protocol addresses:

Factors That Affect Complete Sample Uptake & Retention

Chemical Hazard Concentration	Temperature
Time of Exposure	Humidity
Sorbent Capacity	Interfering Chemicals
Sorbent Strength	Reverse Diffusion from Sorbent Surface
Wind Velocity	Sampler Orientation
Interaction of Any of the Above Factors	

Validation by NIOSH protocol assures that the sample results are a true and total measure of worker exposure.

**SKC Validation follows the NIOSH Validation Protocol.
Certain experiments may have been modified for practical
reasons, or to provide more rigorous tests.**

User Responsibility

The sampler manager should be a professional trained in air sampling and aware of the limitations and advantages of the method being used. It is also very helpful if they have a working relationship with the analytical techniques being used and the requirements of record keeping.

In accordance with ASTM D6346-98 and ANSI 104-1998 standards, use of samplers outside the range of conditions used in these validation tests does not assure accurate results and is not recommended. It is the user's responsibility to determine whether the conditions of the sampling site fall within the range tested. For bi-level validations it can be assumed that the applicable range is that used for testing the lower member of the homologous series.

Workers should be trained in the use of the equipment. In collecting the sample, care should be taken in the location of the sampler on the worker. It is to be openly exposed near the breathing zone. Exact times of exposure must be recorded. No moisture condensation should occur on the sampler. Workers should not be allowed to touch the sampler as they may transfer contamination. Particular attention must be paid to environments where liquid aerosols may be present, since droplets of liquid solvent on the sampler face will invalidate the sample. Any other field conditions outside of the limits used in the NIOSH protocol, such as extreme temperatures or stagnant air conditions which might affect the sampler operation should be recorded.

Good laboratory practice must be followed. Follow the operating instructions for the desorption time needed for complete desorption. Use only the correct desorption instrument. If gas chromatography is used as the analysis method, base line separation should occur with the chemical hazard of interest and proper instrument calibration procedures used.

NIOSH or OSHA analytical methods should be used.

Summary of NIOSH Validation Protocol¹

Characteristic	Experimental Design	Interpretation of Results														
1. Analytical Recovery	Spike 16 samplers, 4 at each of 4 concentration levels (0.1, 0.5, 1.0 & 2.0 x STD) Equilibrate about 12 h and analyze.	For the higher 3 levels require $\geq 75\%$ recoveries with $S_r \leq 0.1$.														
2. Sampling Rate and Capacity	Expose samplers (4 per time period) for 1/8, 1/4, 1/2, 1, 2, 4, 6, 8, 10 & 12 h to 2 x STD, 80% RH and 20 cm/s face velocity. Plot concentration vs. time exposed. Determine MRST and SRST.	Verify sampling rate. State useful range at 80% RH & 2 x STD. Capacity - sample loading corresponding to the downward break in conc. vs time curve from constant concentration. SRST - time linear uptake rate achieved. MRST-0.67 x capacity (1 analyte) MRST-0.33 x capacity (Multi-analyte)														
3. Reverse Diffusion	Expose 20 samplers to 2 x STD. 80% RH for 0.5 x MRST. Remove and analyze 10 samplers. Expose others to 80% RH and no analyte for remainder of MRST.	Require $\leq 10\%$ difference between means of the two sampler sets at the 95% CL.														
4. Storage Stability	Expose 3 sets of samplers (10 per set) at 80% RH, 1 x STD, and 0.5 x MRST. Analyze first set within 1 day, second set after 2 weeks storage at about 25° C, third set after 2 weeks storage at about 5° C.	Require $\leq 10\%$ difference at the 95% CL between means of stored sampler sets and set analyzed within 1 day.														
5. Factor Effects	Test the following factors at the levels shown. Use a 16 -run fractional factorial design (4 samplers per exposure) to determine significant factors.	Indicate any factor that causes a statistically significant difference in recovery at the 95% CL. Investigate further to characterize its effect.														
	<table border="0"> <thead> <tr> <th><u>Factor</u></th> <th><u>Test Levels</u></th> </tr> </thead> <tbody> <tr> <td>analyte concentration</td> <td>0.1 & 2 x STD</td> </tr> <tr> <td>exposure time</td> <td>SRST & MRST</td> </tr> <tr> <td>face velocity</td> <td>10 & 150 cm/s</td> </tr> <tr> <td>relative humidity</td> <td>10 & 80% RH</td> </tr> <tr> <td>interferant</td> <td>0 & 1 x STD</td> </tr> <tr> <td>sampler orientation</td> <td>parallel & perpendicular (to air flow)</td> </tr> </tbody> </table>	<u>Factor</u>	<u>Test Levels</u>	analyte concentration	0.1 & 2 x STD	exposure time	SRST & MRST	face velocity	10 & 150 cm/s	relative humidity	10 & 80% RH	interferant	0 & 1 x STD	sampler orientation	parallel & perpendicular (to air flow)	
<u>Factor</u>	<u>Test Levels</u>															
analyte concentration	0.1 & 2 x STD															
exposure time	SRST & MRST															
face velocity	10 & 150 cm/s															
relative humidity	10 & 80% RH															
interferant	0 & 1 x STD															
sampler orientation	parallel & perpendicular (to air flow)															
6. Temperature Effects	Expose samplers (10 per temp) to 0.5 x STD at 10, 25, & 40° C for 0.5 x MRST	Define temperature effect and verify correction factor, if provided.														
7. Accuracy and Precision	Calculate precision and bias for samplers (10 per conc. level) exposed to 0.1, 0.5, 1 & 2 x STD at 80% RH for \geq MRST. Use data from previous experiments.	Require bias within $\pm 25\%$ of true value at 95% CL with precision $S_r \leq 10.5\%$ for 0.5, 1, & 2 x STD levels.														

Summary of NIOSH Validation Protocol (cont.)

Characteristic	Experimental Design	Interpretation of Results
8. Shelf Life	Observe samplers throughout evaluation for changes in blank values, physical appearance, etc. Test samplers from more than one lot, if possible.	Note shelf storage time at which changes begin to occur. Indicate whether correctable or not.
9. Behavior in the Field	Consider problems not predictable from laboratory experiments.	Record temperature, humidity, air velocity, other contaminants, etc.
<i>Area Sampling:</i>	Expose passive samplers and independent method samplers (13 each) to the same environment.	Calculate precision and bias. Compare with laboratory results.
<i>Personal Sampling:</i>	Conduct personal sampling with ≥ 25 sampler pairs. Place pairs of passive samplers and independent samplers on the same lapel of each worker.	Calculate bias. Compare with area sampling and laboratory results

Bi-Level Validation (previously designated by SKC as 5B)

Validation of passive samplers is essential to ensure accurate determination of airborne chemical levels. To assist manufacturers and users, the National Institute for Occupational Safety and Health (NIOSH), the Health and Safety Executive (HSE)², and the Comité Européen de Normalisation (CEN)^{3,4} have developed comprehensive protocols for the validation of passive samplers.

Bi-level validation can also be used to assure a sample that gives the total and complete exposure to a chemical hazard.

Bi-level validation is only for a series of chemically related compounds, i.e., members of a homologous series. Bi-level validation includes a full protocol validation on key compounds followed by a partial validation on other members of the series.

The concept of a bi-level validation of chemically related compounds for a given sorbent and sampler design is based on the following premises and has been studied by Guild et al.⁵

1. Full validation by NIOSH, HSE, or CEN Protocol of a lower member of the series is essential to assure accurate, routine sampling under all field conditions without the need for error-corrective measures.
2. Capacity and retentivity are directly related to the affinity of a sorbent for a specific chemical. For a series of chemically related compounds, the affinity of a sorbent for a particular member compound will increase with the molecular weight and boiling point of the member. If a sorbent is suitable for collecting a low molecular weight member of the series, it will be suitable for the higher molecular weight members of the series as well.
3. For chemically stable compounds, sample loss by reverse diffusion and loss during storage are inversely related to the affinity of the sorbent for the adsorbate. Therefore, compounds with higher molecular weights and boiling points will exhibit less loss by reverse diffusion and storage. Again, if a sorbent is suitable for a member with a lower molecular weight and boiling point, it will be suitable for the higher members.
4. The linearity of uptake with time is also a function of sorbent affinity and capacity. Uptake becomes increasingly linear as the molecular weight and boiling point increases and the sample load decreases. (Protocol validation requires study of concentrations ranging from 0.1 to 2.0 x the permissible exposure limit.)

Bi-Level Validation (cont.)

5. Temperature affects the accuracy of passive samplers in two different ways; the relation of temperature to adsorption affinity and the relation of the molecular diffusion of the sample to the sampler.
 - a. It is well known that the affinity of a sorbent for a chemical decreases with increasing temperature. If the sorbent has adequate affinity for a low molecular weight member of the series at 40° C (the maximum temperature tested under protocol), it will also be adequate at lower temperatures, and for higher molecular weight members of the series.
 - b. The effects of temperature on sample uptake follow established mathematical relationships and are not significant compared to other random sampling errors.
6. The effects of humidity because of competition or modification of sorbent affinity will be most pronounced for lower members of the series.
7. Adsorption affinity decreases with the mass adsorbed. Therefore, the “key” member chosen for full validation should have a high PEL relative to the other members of the series.
8. Air velocity and sampler-orientation effects are functions of sampler design and will be similar for all compounds.
9. If all the factors affecting sampling accuracy improve with increasing molecular weight and boiling point and there are no interacting effects of these parameters with a lower member of the series, then there will be no interacting effects with higher members.
10. The accuracy of a sampler is determined by its bias and precision. For most passive samplers, the bias is the result of the deviation of the calculated sample rate from the actual rate. By determining the sample rate under known conditions at 1 PEL, the bias is reduced to zero. Therefore, measured sample rates should be determined for all compounds.
11. The precision of a sampler is a function of the consistency of sampler manufacture and the analytical procedures in the laboratory.
12. Analytical recovery tends to decrease with increased sorbent affinity and is a function of the chemical compound, the concentration, and the sorbent. Therefore, analytical recovery should be determined for every compound over the concentration range of 0.1 to 2.0 PEL, as recommended by protocol.

Conclusion: The above premises have been verified, peer reviewed and published.⁵ Therefore, Bi-Level validation (5B) is an excellent way to assure accurate performance of a passive sampler for higher members of a homologous series.

Comments on the Relationship Between the NIOSH and CEN Diffusive Sampler Evaluation Protocols

The Comité Européen de Normalisation (CEN) is engaged in writing standards for air sampling equipment which include the limitations on precision and accuracy (EN 482) and the required performance tests. In the case of passive samplers the relevant performance test standard is yet to be published, but draft copies are available (prEN 838).

The precision and accuracy requirements in EN 482 are based on the use that will be made of the results, principally either for problem identification or compliance purposes. The standard for compliance purposes is a combined precision and accuracy of less than 30%, which is a looser standard than the 25% in the NIOSH protocol.

The performance tests are closely related to those in the NIOSH protocol, as might be expected, since they are trying to confirm the performance of the samplers over a similar range of environmental conditions. As in the NIOSH protocol there are tests for desorption efficiency, uptake rate at different concentrations and for different time-periods, reverse diffusion, storage stability, wind velocity and orientation, humidity, temperature, and the presence or absence of interferences. As in the NIOSH protocol these factors are normally tested using a "high" and a "low" measure, whether alone or in combination. Since there is little difference between workplace conditions in the U.S.A. and Europe, these "high" and "low" conditions are very similar in the two protocols. In general, the NIOSH test provides the more stringent conditions (e.g. 7.5 minutes up to 12 hours in the NIOSH uptake rate experiment versus 30 minutes and 8 hours in the CEN equivalent). In addition, for the majority of the experiments, the NIOSH protocol requires more samples to be taken for each data point (typically 10 rather than 6). The reverse diffusion test is one test that might be considered significantly different, and a paper showing that the results of the tests are actually comparable has been submitted for publication.⁶

In addition, the CEN protocol requires tests for shelf-life and packaging integrity that have been carried out for one analyte (n-Hexane) only. The 575 Series passive sampler successfully passed these tests.

For the reasons given above, SKC considers the validations presented in these research reports to be at least sufficient to meet the requirements of the European Standards prEN 838 and EN 482 for compliance monitoring. This conclusion is supported by a detailed comparison which has been submitted for publication.⁷

The CEN protocol supports the Bi-level theory of validation.

SHELF-LIFE STUDY ON 575 SERIES PASSIVE SAMPLERS

Protocol: 4 expired and 2 unexpired 575-001 samplers were exposed to an atmosphere 100 ppm n-Hexane (2 X PEL) at 80% relative humidity (25° C) for 30 minutes, and then analyzed. Study was conducted August 1995.

Results:

Calculated atmosphere concentration:	106 ppm
Gas sample analysis concentration:	102 ppm (RSD = 7.0%)
Sorbent tube analysis concentration:	115 ppm (RSD = 3.2%)
Sampler analysis concentration: [◇]	
Sampler expired 12/92:	106 ppm
Sampler expired 4/94:	106 ppm
Sampler expired 10/94:	108 ppm
Sampler expired 10/94:	110 ppm
Sampler unexpired (7/96):	100 ppm
Sampler unexpired (7/96):	100 ppm

[◇] Based on 111.6% desorption efficiency

Conclusion: Samplers will perform as expected up to their expiration date.

PACKAGING INTEGRITY STUDY ON 575 SERIES SAMPLERS

Protocol: 6 575-001 samplers in unopened Tedlar® pouches were exposed to an atmosphere of 100 ppm n-Hexane (2 X PEL) at 80% relative humidity (25° C) for four hours, and then opened and analyzed.

Results:

Calculated atmosphere concentration:	103 ppm
Gas sample analysis concentration:	104 ppm (RSD = 8.7%)
Sorbent tube analysis concentration:	103 ppm (RSD = 2.7%)

Sampler analysis: No detectable n-Hexane in any sampler.

(estimated LOD = 1.5 micrograms, equivalent to 0.125 ppm)

Conclusion: Packaging will prevent contamination of stored samplers.

Scope of the Method

Analyte:	2-Butanone (MEK)
Matrix:	Air
Procedure:	Adsorption on a 575-002 SKC passive sampler, desorption with 2 ml of 5% 2-butanol in carbon disulfide, and analysis by GC-FID.
Exposure Guidelines:	ACGIH-TLV (1994/95) 200 ppm TWA OSHA (1995) 200 ppm TWA, 300 ppm STEL NIOSH (1995) 200 ppm TWA, 300 ppm STEL

Validation Range, Recovery:

<u>Compound</u>	<u>Validation Range ppm in air</u>	<u>Mean % Recovery</u>
MEK	20 - 400	100

Detection Limits: The limit of detection (LOD) as defined by a 3:1 signal to noise ratio was 5 µg/badge. This corresponds to a LOD in air of 0.2 ppm (v/v) based on an 8 hour sample at the validated sampling rate of 17.1 ml/min.

Humidity Effects: High humidity conditions (80% RH at 25° C) did not affect the recovery of MEK on the 575-002 passive sampler.

Storage Effects: The passive sampler can store for at least 25 days at freezer (-8°C) temperatures with with no significant loss in recovery. Precautions must be taken at ambient temperatures. Average recoveries after 4 days of storage was 76.9%. Refrigerated shipment of samples is recommended.

Interferences: Any compound that has the same retention time as MEK will interfere with the analysis.

Validation Completion Date: November 1992

Physical Properties:

<u>Mol. Weight (g/mole)</u>	<u>Boiling Pt. at 760 mm Hg</u>	<u>Density (g/ml)</u>
72.12	80° C	0.8054

Background

History of Methodology

Previous methodologies have used PCB activated charcoal and silica gel. MEK is not stable on Lot 120 charcoal, particularly at high relative humidity. The stability is much better on silica gel but the capacity is quite low, so that 2 tubes in series had to be used to adequately collect MEK.

Research Purpose

The present work was to evaluate and validate the SKC 575 Series passive sampler containing Anasorb 747 as a method for sampling MEK. The passive sampler was validated over a concentration range of 20 - 400 ppm. Critical parameters such as analytical recovery, concentration, relative humidity, and storage stability were addressed.

Experimental

99% pure MEK (Fisher Scientific) was used. The HPLC-grade carbon disulfide (99.9%) was obtained from Aldrich Chemical Company. The 575 passive sampler containing Anasorb 747 (SKC Cat. No. 575-002) and the Anasorb 747 tubes used for atmosphere calibrations (SKC Cat. No. 226-81) are available from SKC, Inc.

A dynamic atmosphere generation apparatus was used to generate precise concentrations of MEK in air for exposure of the passive samplers. The system is described in Appendix A and Figure 1. The atmosphere was fed into an exposure test chamber. The passive samplers were exposed on a rotating bracket inside the test chamber to simulate wind velocity and orientation.

Analytical recoveries for the passive samplers were conducted by injecting a known amount of MEK (as a CS₂ solution) into the back of each sampler. The passive samplers were capped, allowed to equilibrate overnight, and analyzed the next day to determine analytical recovery or desorption efficiency. The tests were conducted at mass loadings equivalent to an 8-hour time weighted average sample (8.21 L based on a calculated sampling rate of 17.1 ml/min) at 0.1, 0.5, 1.0 and 2.0 PEL under dry conditions.

The sampling rate, analytical recovery and storage stability experiments on the passive sampler were conducted under dynamic conditions in the test chamber described above. In the storage stability study, recovery is referred back to the reference samples analyzed on Day 1.

The passive samplers were desorbed (in situ) with 2 ml of carbon disulfide containing 5% 2-butanol and shaken on a flatbed shaker for 30 minutes. All extracts were transferred to autosampler vials and analyzed by flame ionization gas chromatography. A chromatogram with analytical conditions is shown in Figure 2.

Sampling Rate Determination

Sampling rates can be determined by one of several statistical methods from the experimental data and they differ by only a small amount. Any bias taken is toward the protection of the worker.

We use the time-weighted average from one to eight hours where results fall within NIOSH criteria.

We constantly review our data and conduct experimental work to provide the most precise sampling rate. This rate may differ slightly from previously published sampling rates. Use the rate listed in this report.

Analytical Recovery

2-Butanone (MEK)

NIOSH Requirements

Experimental Design

Spike 16 samplers, 4 at each of 4 concentration levels (0.1, 0.5, 1.0 & 2.0 x STD) Equilibrate about 12 h and analyze.

Interpretation of Results

For the 3 higher levels require $\geq 75\%$ recoveries with $S_r \leq 0.1$.

Results

PEL Level	Spike (μg)	Recovery (μg)	Recovery %	Mean	RSD %
0.1	471.3	455.8	96.7	101	5.6
		514.2	109		
		459.6	97.5		
		476.7	101		
0.5	2416.2	2443.9	101	100	0.7
		2400.6	99.4		
		2407.9	99.7		
		2408.6	99.7		
1.0	4824	4686.7	97.0	98.4	1.1
		4753.5	98.4		
		4766.7	98.6		
		4817.6	99.7		
2.0	9664.8	9710.9	100	100	0.57
		9694.0	100		
		9768.4	101		
		9768.3	101		
Overall Mean			99.98		

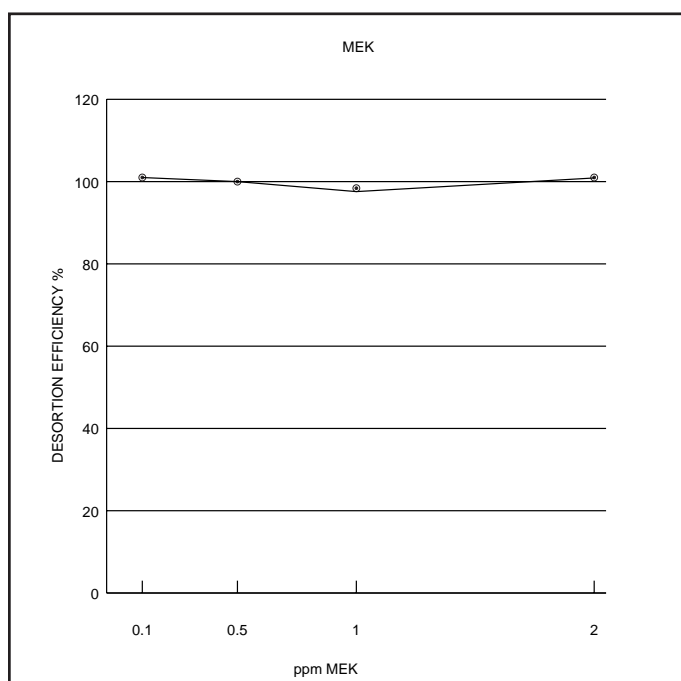

See Analytical Recoveries on p. 11 for explanation.

Sampling Rate and Capacity

2-Butanone (MEK)

NIOSH Requirements

Experimental Design

Expose samplers (4 per time period) for 1/8, 1/4, 1/2, 1, 2, 4, 6, 8, 10 and 12 h to 2 x STD, 80% RH and 20 cm/s face velocity. Plot concentration vs. time exposed. Determine MRST and SRST.

Interpretation of Results

Verify sampling rate. State useful range at 80% RH and 2 x STD. Capacity - sample loading corresponding to the downward break in conc. vs time curve from constant concentration. SRST-time linear uptake rate achieved. MRST - 0.67 x capacity (1 analyte)
MRST-0.33 x capacity (Multi-analyte)

Results

Time (hrs)	Uptake μg	Mean μg	RSD %	DE Corr μg	Conc. (ppm)
0.125	77.4	77.99	3.5	77.99	206.2
	81.0				
	74.6				
	78.96				
0.25	144.2	140.6	3.7	140.6	185.8
	142.5				
	142.6				
0.50	132.9	283.6	2.7	283.6	187.4
	281.0				
	295.1				
1.0	280.0	602.95	4.9	602.95	180.0
	278.2				
	620.0				
	607.7				
2.0	624.2	1089.5	3.6	1089.5	179.8
	559.9				
	1060				
	1066				
4.0	1086	2177	4.2	2177	171.5
	1146				
	2124				
	2086				
6.0	2210	3113.8	6.3	3113.8	174.6
	2288				
	2926				
	3175				
8.0	2992	4226.8	5.0	4226.8	172.9
	3362				
	4324				
	4148				
10.0	4463	5231.2	3.0	5231.2	177.9
	3972				
	5415				
	5304				
12.0	5070	6459.8	3.1	6459.8	177.9
	5136				
	6756				
	6324				
	6381				
	6378				

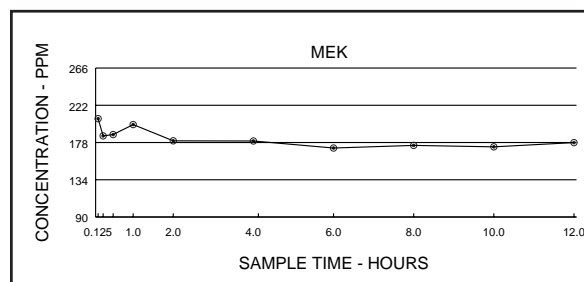
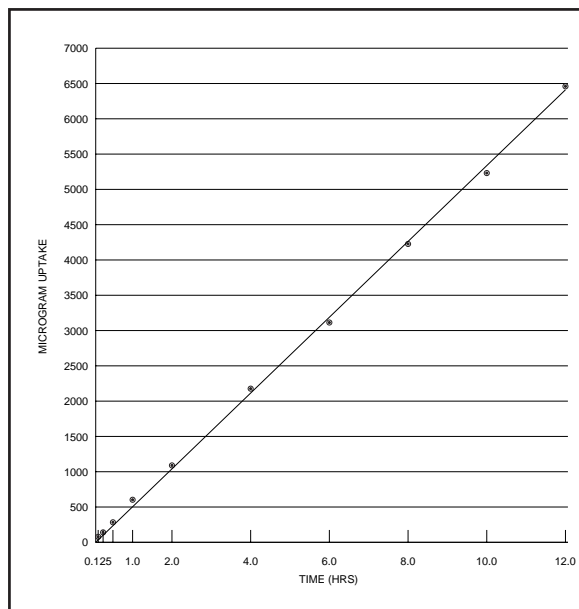

The mean sampling rate was 17.1 ml/min and was calculated as a weighted average of the 1, 2, 4, 6, & 8 hour exposure period, based on a mean concentration of 176 ppm.

Storage Stability

2-Butanone (MEK)

NIOSH Requirements

Experimental Design

Expose 3 sets of samplers (10 per set) at 80% RH, 1 x STD, and 0.5 x MRST. Analyze first set within 1 day, second set after 2 weeks storage at about 25° C, third set after 2 weeks storage at about 5° C.

Interpretation of Results

Require $\leq 10\%$ difference at the 95% CL between means of stored sampler sets and set analyzed within 1 day.

Results

Room Temperature (25° C)			Freezer (-8° C)		
Storage Conditions	Des Eff Corr (µg)	Mean µg	Storage Conditions	Des. Eff Corr (µg)	Mean µg
Day 1	4771.7	4520.3	Day 1	4012.2	3902.2
	4268.9			3792.2	
Day 8	3145.9	3275.8	Day 7	3794.2	3953.6
	3428.6			3830.4	
Day 15	3252.9	2763.5	Day 14	4236.3	3734.1
	2757.3			3504.6	
Day 20	2775.6	2466.4	Day 25	3840.6	3626.8
	2757.6			3857.3	
	2378.7			3704.0	
	2453.6			3627.5	
	2566.9			3548.9	

There is no significant loss (<10%) of sample on storage at freezer (-8° C) temperatures.

Appendix A

Atmosphere Generation Apparatus

The instrument is designed to expose a known concentration of a chemical hazard to a passive sampler under controlled conditions of: 1. Concentration, 2. Temperature, 3. Humidity, 4. Wind Velocity Effect, 5. Time, and 6. Up to four multicomponent hazards.

Description

The instrument consists of:

1. an exposure chamber in which the wind velocity effects are controlled by internal rotating holders,
2. an air supply and purification train such that dry air is blended with saturated air under desired temperature conditions so as to provide air at a known flow and selectable humidity,
3. an injection system composed of precision motor driven syringes in which 1 to 4 chemical hazards can be injected into the flow system and in which the temperature of the injectors is closely controlled,
4. an electrical control system that controls the entire instrument operation,
5. the chamber concentration can be verified by either solid sorbent sampling tubes actively sampled or by gas analysis of the gas phase. The particular verification method used will depend on the analyte of interest.

Means are also included to check the relative humidity.

Figure 1
 Atmosphere Generation Apparatus

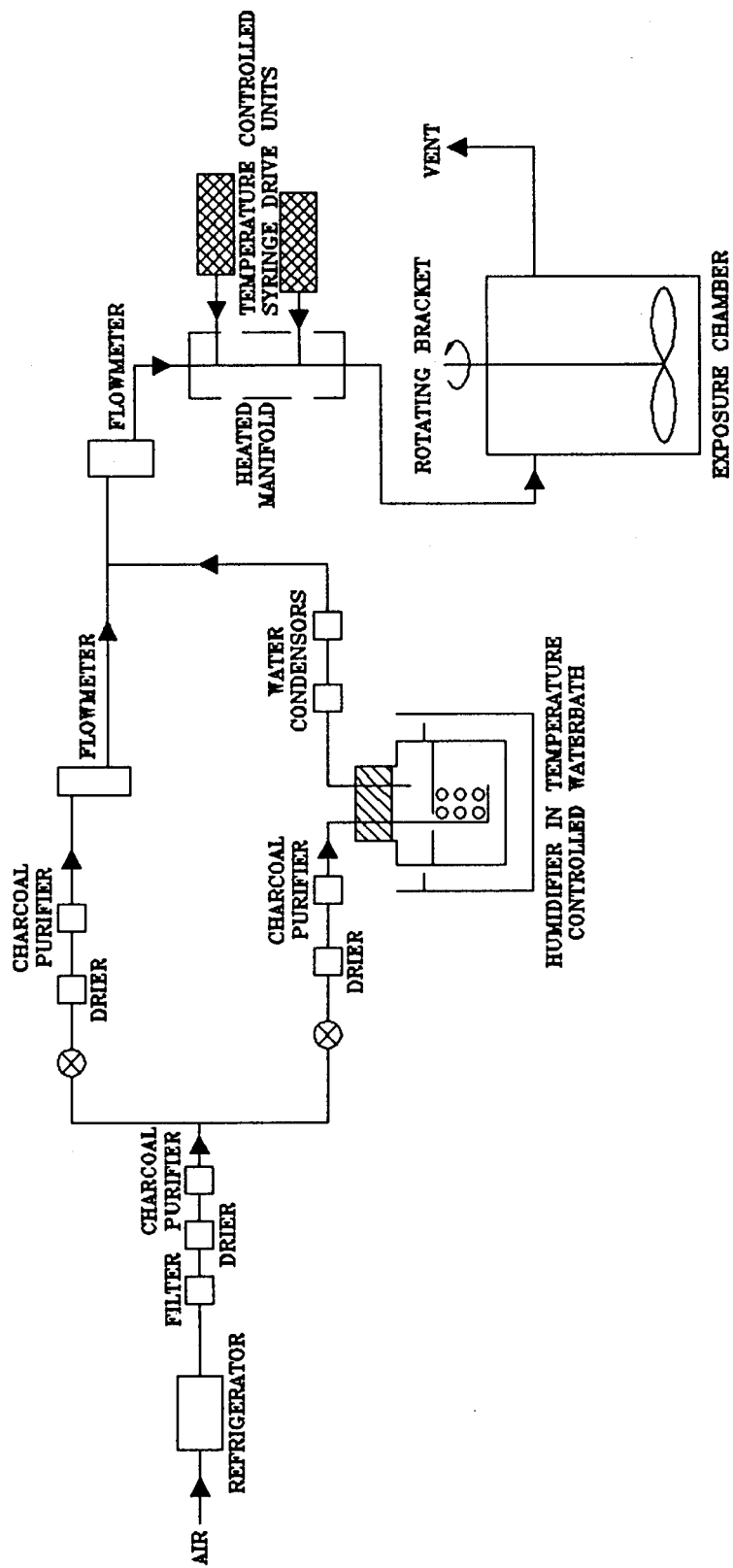
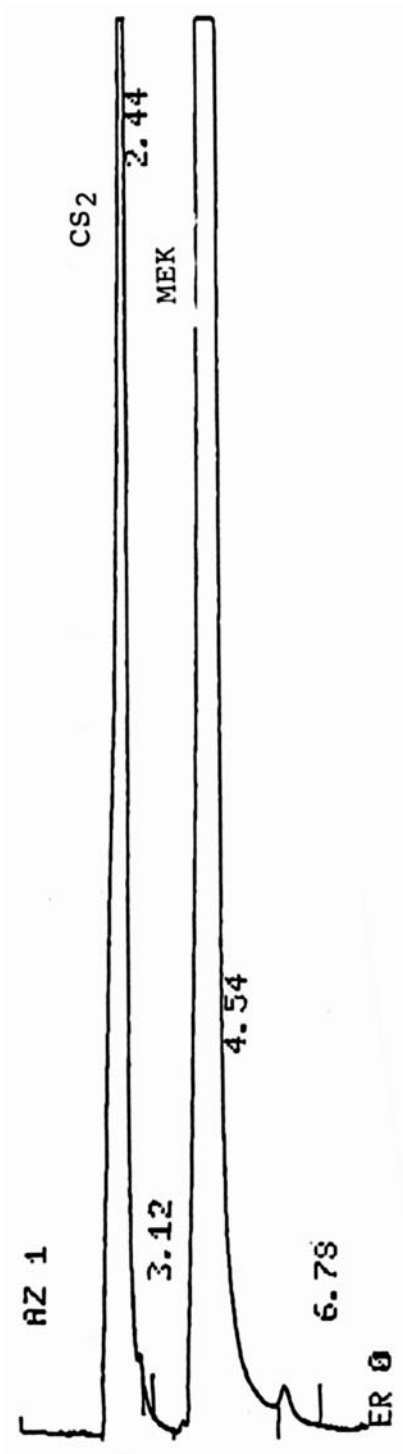

Figure 2
Analytical Instrument

Sample Chromatogram
MEK in CS₂



GC Conditions

Column: 10 x 1/8" 10% SP-1000
on 80/100 Supelcoport

Temperatures: Column: 85° C
FID: 150° C

Carrier Gas: N₂ at 20 ml/min

Injection: 1µL

Abbreviations

C	Celsius
CL	confidence level
cm	centimeter
ml	milliliter
min	minute
g	gram
GC-FID	gas chromatography - flame ionization detector
h	hour
L	liter
LOD	limit of detection
MRST	maximum recommended sampling time
N.S.	not significant
PEL	permissible exposure limit
RH	relative humidity
TLV	threshold limit value
TWA	time-weighted average
RSD	relative standard deviation
SD	standard deviation
SRST	shortest recommended sampling time
STD	the appropriate exposure standard (OSHA PEL, ACGIH TVA , or NIOSH recommended standard)
S	second
S_r	Pooled relative standard deviation
V	volume

Trademarks

Anasorb is a registered trademark of SKC Inc.

Tedlar is a registered trademark of DuPont Corporation.

Porapak is a registered trademark of Waters Associates, Inc.

Supelcoport is a registered trademark of Supelco, Inc.

References

1. Cassinelli, M.E., Hull, R.D., Crable, J.V. and Teass, A.W., "Diffusive Sampling: An Alternative to Workplace Air Monitoring," A. Berlin, R.H. Brown and K.J. Saunders (Royal Society of Chemistry, London) (eds.), NIOSH Protocol for the Evaluation of Passive Monitors, 1987: p 190-202.
2. Brown, R.H., Harvey, R.P., Purnell, C.J., and Saunders, K.J., "A Diffusive Sampler Evaluation Protocol." Am. Ind. Hyg. Assoc. J. 45:67-75 (1984).
3. CEN/TC137/WG2 (1993) EN 482. Workplace Atmospheres - General Requirements for the Performance of Procedures for the Measurement of Chemical Agents. Comité Européen de Normalisation, Brussels, Belgium.
4. CEN/TC137/WG2 (1995) prEN 838. Workplace Atmospheres - Diffusive Samplers for the Determination of Gases and Vapours - Requirements and Test Methods. Comité Européen de Normalisation, Brussels, Belgium.
5. Guild, L.V., Myrmel, K.H., Myers, G. and Dietrich, D.F., "Bi-Level Passive Monitor Validation: A Reliable Way of Assuring Sampling Accuracy for a Larger Number of Related Chemical Hazards," Appl Occup Environ Hyg, Vol 7, No. 5, May 1992, pp. 310-317.
6. Harper, M., Fiore, A.A., Fiorito, D.L. and O'Lear, C., "Comparison of the Tests for Non-ideal Behaviour by Reverse Diffusion in the NIOSH and CEN Diffusive Sampler Evaluation Protocols," Submitted to Ann. Occup. Hyg. (1995).
7. Harper, M., Guild, L.V., "Levels of Validation - Experience in the Use of the NIOSH Diffusive Sampler Evaluation Protocol," Submitted to Am. Ind. Hyg. Assoc. J. (1995).

Validation of 2-Butanone (MEK)
using
SKC Passive Sampler
575-002

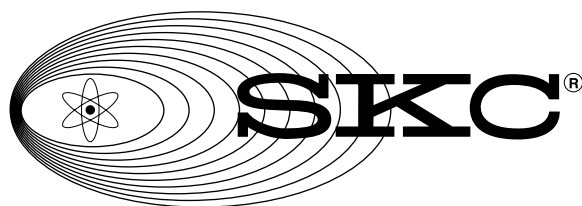

SKC Inc.
863 Valley View Road
Eighty Four, PA 15330

Contents

Abstract.....	1
Importance of Validation of Passive Samplers.....	2
Summary of NIOSH Validation Protocol.....	4
Bi-Level Validation.....	6
Comments on the Relationship Between the NIOSH and CEN Diffusive Sampler Evaluation Protocols.....	8
Scope of the Method.....	10
Background.....	11
Analytical Recovery.....	12
Sampling Rate and Capacity.....	13
Storage Stability.....	14
Appendix A. Atmosphere Generation Apparatus.....	15
Figure 1. Atmosphere Generation Apparatus.....	16
Figure 2. Analytical Instrument.....	17
Abbreviations, Trademarks.....	18
References.....	19